

# GDF46-18Z/1.5 220V Outline diagram

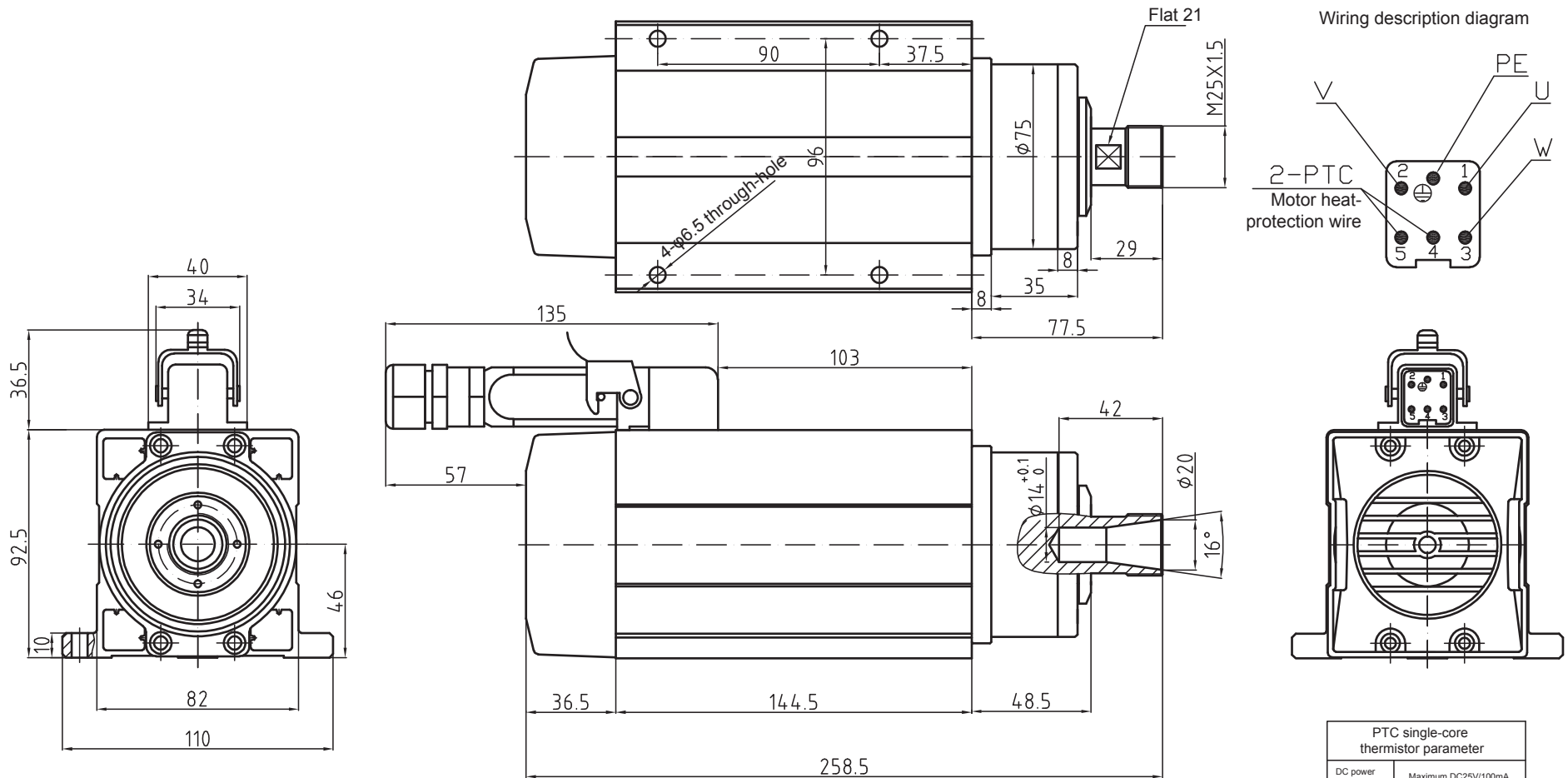

Weight: 6KG  
 ER nut: ER20  
 Cooling method: air cooling  
 Bearing lubrication method: grease lubrication  
 High-precision angular contact ball bearing: 2×7005C P4/1×7002C P4

Power 1.5 kw  
 Voltage 220 V  
 Current 5.6 A  
 Frequency 300 Hz  
 Rotating speed 18000 r/min

Rotating direction: anticlockwise from the shaft extension end

Special attention: thread locking adhesive shall be applied or the spring washer shall be added to prevent the looseness during the installation of the fastening screw!

PTC single-core thermistor parameter	
DC power supply	Maximum DC25V/100mA
-20~25℃	≤100Ω
≤90℃	≤250Ω
105℃	≤550Ω
110℃	Rated operating temperature
115℃	≥1330Ω
≥125℃	≥4KΩ
≤160℃	Maximum storage temperature