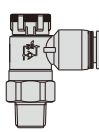
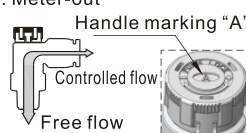
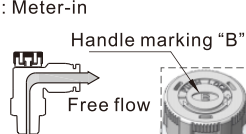

PTL Mini series

Ordering code

PTL 6 01 A □ □ -M

① ② ③ ④ ⑤ ⑥ ⑦

① Model	② Port size	③ Thread connection	④ Control method	⑤ Standard color	⑥ Thread type	⑦ Style
PTL: Speed controller (Push lock) 	4: $\Phi 4\text{mm}$ 6: $\Phi 6\text{mm}$	01: 1/8"	A: Meter-out 	Standard color: Specification Blank: Gray	Blank: PT	M: Mini type
			B: Meter-in 	D: Black Release button: Black Body: Black		

Specification

Operating pressure range	0~10kgf/cm²(0~1.0MPa)
Negative pressure	-750mmHg(10Torr)
Proof pressure	1.5MPa
Ambient and fluid temperature (°C)	-20~70
Applicable tubing	Soft nylon or polyurethane
Color	Gray/black

Symbol

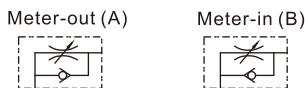

Selection, Installation and Operation

- The rotation torque of the push-lock speed controller cap should not be too large to avoid damage. It is recommended to use the torque below.

Thread size	Recommended torque(N.m)
1/8"	0.08

- Push-lock speed controller installation instructions is the same as general one. Please refer to general type for specific content.

Dimensions

PTL Mini series

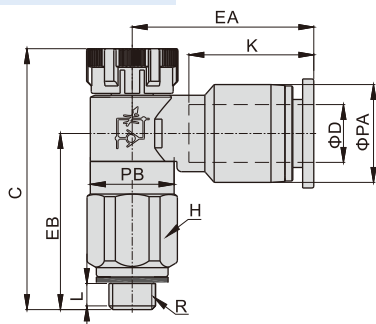

Model\Item [Note1]	ΦD	R	ΦPA	ΦPB	L	C		K	EA	EB	H	Weight (g)	PCS/bag
						Pull	Push						
PTL401□-M	4	PT1/8	8.5	9	3.5	29.5	28	12.5	16.5	19	10	11	2
PTL601□-M	6	PT1/8	10.5	9	3.5	29.5	28	13.5	19.5	19	10	12	2

[Note1] "□" stands for A or B. A indicates meter-out type while B indicates meter-in type. The two types are with the same overall dimension.

PTL series

Ordering code

PTL 6 01 A □ □
 ① ② ③ ④ ⑤ ⑥

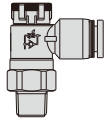
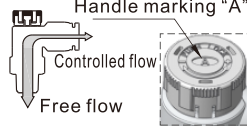
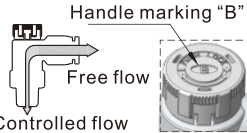
① Model	② Port size	③ Thread connection	④ Control method	⑤ Standard color	⑥ Thread type
PTL: Speed controller (Push lock) 	6: Φ6mm	01: 1/8" 02: 1/4" 03: 3/8"	A: Meter-out  Handle marking "A" Controlled flow Free flow	Standard color	Blank: PT
	8: Φ8mm	01: 1/8" 02: 1/4" 03: 3/8" 04: 1/2"		B: Meter-in  Handle marking "B" Controlled flow Free flow	
	10: Φ10mm	02: 1/4" 03: 3/8" 04: 1/2"	D: Black		
	12: Φ12mm	03: 3/8" 04: 1/2"			

Specification

Operating pressure range	0~10kgf/cm²(0~1.0MPa)
Negative pressure	-750mmHg(10Torr)
Proof pressure	1.5MPa
Ambient and fluid temperature (°C)	-20~70
Applicable tubing	Soft nylon or polyurethane
Color	Gray/black

Product feature

1. Compare with standard speed controller, smaller size, lighter weight, suitable for more occasions.
2. Effectively control the action speed and the pressure signal transmission from pneumatic device.
3. Simple push-lock, operation.
4. Adjust quickly, easily and accurately.
5. Excellent flow rate characteristic, high sensitivity and easy to adjust.
6. Options of Meter-out and meter-in, applicable for every type actuator.
7. Effectively prevent from corrosion and pollution by nickle plated copper.
8. The sealant being coated on threaded portion can ensure no leakage of the threaded connection part.

Symbol

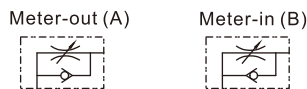

Table for interface port and tube O.D.

Product series	Thread type	Port size			
		Φ6	Φ8	Φ10	Φ12
PTL	1/8"	●	●		
	1/4"	●	●	●	
	3/8"	●	●	●	●
	1/2"		●	●	●

Selection, Installation and Operation

1. The rotation torque of the push-lock speed controller cap should not be too large to avoid damage. It is recommended to use the torque below.

Thread size	Recommended torque(N.m)
1/8"	0.08
1/4"	0.16
3/8"	0.24
1/2"	0.32

2. Push-lock speed controller installation instructions is the same as general one. Please refer to general type for specific content.

Inner structure

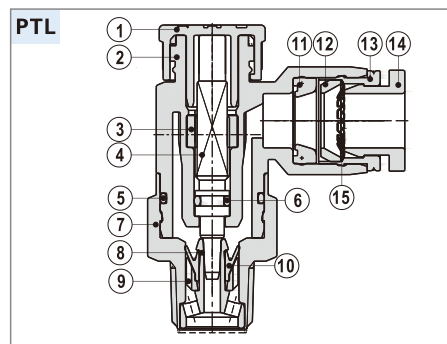

NO.	Name	Material	NO.	Name	Material
1	Adjusting cap	POM	9	Holder	PBT
2	Plastic body	PBT	10	O-ring	NBR
3	Locating ring	Aluminum alloy	11	O-ring	NBR
4	Throttling column	Aluminum alloy	12	Locating seat	POM
5	O-ring	NBR	13	Locating ring	Aluminum alloy
6	O-ring	NBR	14	Plastic interface	POM
7	Throttling body	Brass	15	Spring gasket	Stainless steel
8	Throttling sleeve	Aluminum alloy			

PTL series

Dimensions

PTL Series

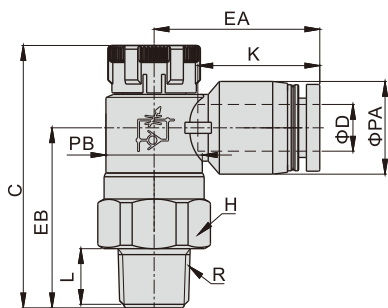

Model\Item [Note1]	ΦD	R	ΦPA	ΦPB	L	C		K	EA	EB	H	Weight (g)	PCS/bag
						Pull	Push						
PTL601□	6	PT1/8	12.5	13	8.5	36	34.5	16.5	22.5	23.5	14	12.5	2
PTL602□		PT1/4	12.5	16.5	11	40.5	39	16.5	24	28	17	19.5	2
PTL603□		PT3/8	12.5	19	12	44	42.5	16.5	25.5	31	19	28.5	2
PTL801□	8	PT1/8	15	13	8.5	36	34.5	18.5	24.5	22.5	14	13	2
PTL802□		PT1/4	15	16.5	11	40.5	39	18.5	26	27	17	20.5	2
PTL803□		PT3/8	15	19	12	44	42.5	18.5	27	30	19	29	2
PTL804□	10	PT1/2	15	24	15	52.5	51	18.5	29.5	37.5	24	49	2
PTL1002□		PT1/4	18	16.5	11	40.5	39	21	31	26	17	22	2
PTL1003□		PT3/8	18	19	12	44	42.5	21	29	29	19	30.5	2
PTL1004□	12	PT1/2	18	24	15	52.5	51	21	31.5	36.5	24	50.5	2
PTL1203□		PT3/8	21	19	12	44	42.5	23	34.5	28	19	32.5	2
PTL1204□		PT1/2	21	24	15	52.5	51	23	34	36	24	53	2

[Note1] "□" stands for A or B. A indicates meter-out type while B indicates meter-in type. The two types are with the same overall dimension.

Flowrate characteristic

Controlled flow rate

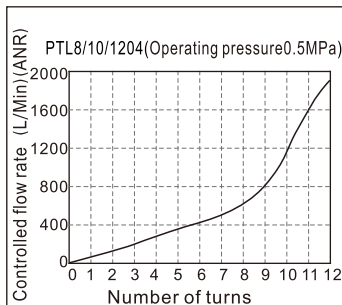
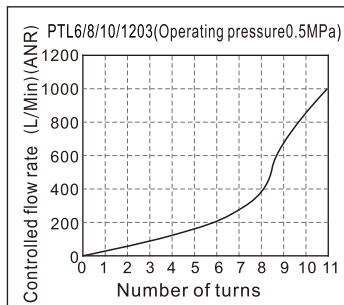
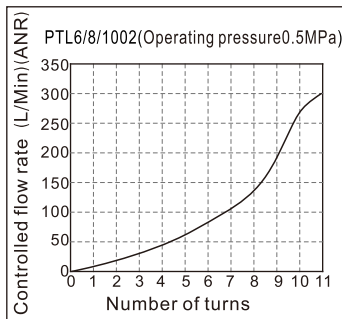
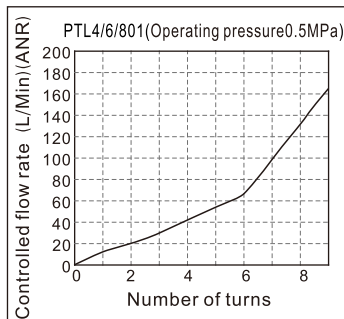
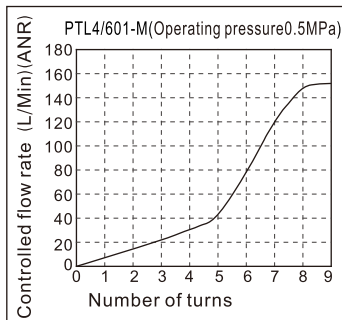

Free flow rate

