

# GDF46-18Z/2.2 220V Outline diagram

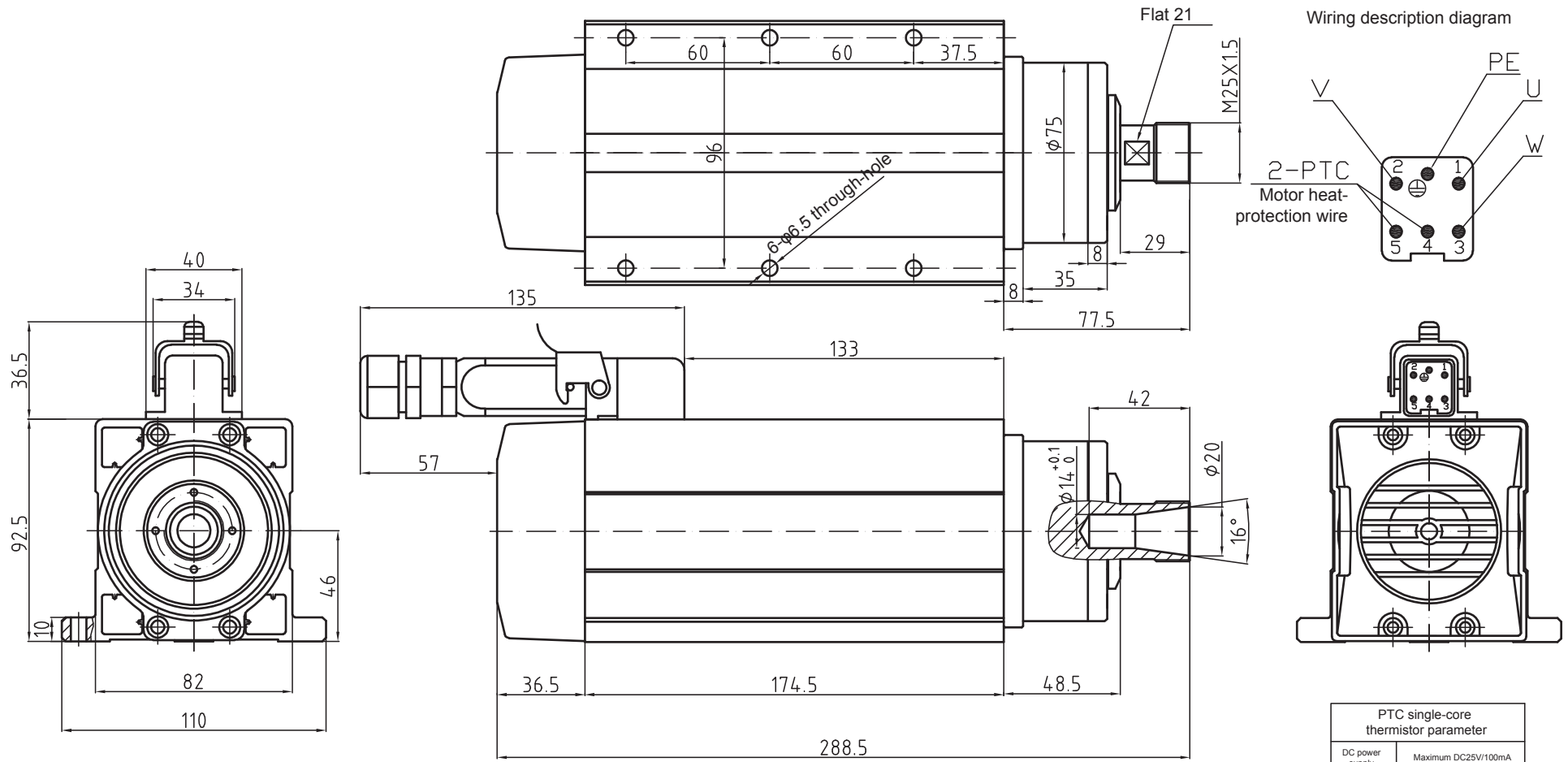

GDF46-18Z/2.2

Weight: 7KG

Power 2.2 kw

ER nut: ER20

Voltage 220 V

Cooling method: air cooling

Current 7.8 A

Bearing lubrication method: grease lubrication

Frequency 300 Hz

High-precision angular contact ball bearing: 2×7005C P4/1×7002C P4

Rotating speed 18000 r/min

Rotating direction: anticlockwise from the shaft extension end

PTC single-core thermistor parameter	
DC power supply	Maximum DC25V/100mA
-20~25℃	≤100Ω
≤90℃	≤250Ω
105℃	≤550Ω
110℃	Rated operating temperature
115℃	≥1330Ω
≥125℃	≥4KΩ
≤160℃	Maximum storage temperature

Special attention: thread locking adhesive shall be applied or the spring washer shall be added to prevent the looseness during the installation of the fastening screw!