

Hole pattern of 1050 FME-W DI for installation at the portal

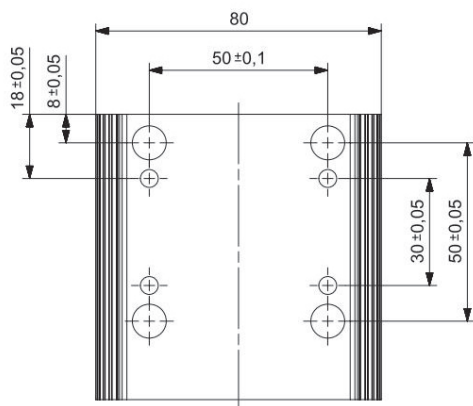

Function tool change with manual pneumatic control

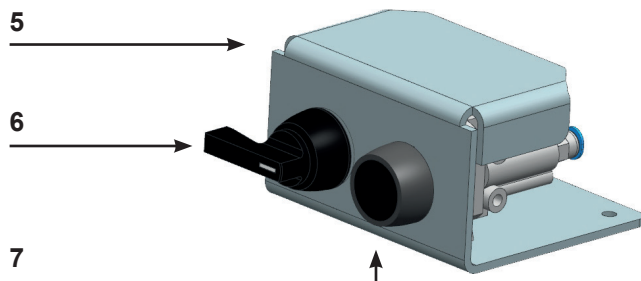

- 5 **Manual pneumatics control** (optionally available - order no.: 98045320)
- 6 **Selection switch „Open/Fixing“** (Pneumatic connection 1)
- 7 **Push button „Output/Blow out“** (Pneumatic connection 2)

The oscillation of the ejector mechanism is achieved by repeated pressing of the push button (break about 300ms).

GB

Programming guide for tool change system

1 Portal connection (three-core)

- brown: 10 – 26 V DC
for power supply
- green: 0 – 10 V DC
for motor speed control
- white: 0 V for GND/ ground

2 Pneumatic connection 1 (6mm)

„for open and fixing the tool holder“

3 Pneumatic connection 2 (6mm)

„for output and blow out the tool holder“

4 Tool holder SK20

incl. clamping nut ER16



Important information about the system

This tool change system was designed under the premise of saving maximum weight of the whole system while improving the milling pattern. Only then is it possible to build a system by a kilowatt of power with just three kilograms of weight. This allows higher dynamics for smaller portals.



As opposed to conventional tool changers, which require a large piston mass for output, the AMB system works with a flight piston. This oscillates in the cylinder of the tool spindle (patent pending), like of a pneumatic hammer drill. The complete system works with the pulse energy of the impinging air piston on the output.

The oscillation is realized by appropriate programming of the portal control.

Information on connection

Please use compressed air hoses with a diameter of 6 mm and a length of max. 3 m. The optimum compressed air supply is between 6 and 8 bar.

Information on programming

-  Change tool only when drive switched off !!!
-  Ensure, that the compressed air supply must not be opened during motor running !!!

Output and clean the tool holder

Step	Function
1	Valve 1 „Open/Fixing“ open
2	Valve 2 „Output/Blow out“ open (time 500ms)
3	Valve 2 „Output/Blow out“ close (time 500ms)
Repeat steps 2 and 3 three to four times so that the flying piston can oscillate and the tool holder is solved safely.	



*The valve timing may vary depending on the manufacturer.
When valve 2 is operated, this is at the same time the exhaust air to cleansing the cone.*

Before recording the new tool, valve 2 must be unoperated because otherwise forms an air cushion, which makes the inclusion of the cone difficult or even impossible.



*For the final security, whether a tool holder was stored safely,
we recommend photocell monitoring for all tools storage spaces.*

Function: Portal control

When the millilling motor is installed at the portal, now you are able to control the motor speed stepless between 5.000 and 25.000 rpm only over the portal. The settings are dependent on the features of the portal or on the used software. Please comply the specifications of the third-party portal supplier. Please note: if you turn on the device, the motor starts only when the input power signal comes from the portal control.

Further hints on handling of the milling motor and safety are described in the enclosed original operating instruction.