

Speed mode start up guide

Safety

This is a comprehensive set of the safety instructions. For full safety instructions see the motor manual, available at www.simplexmotion.com

⚠ CAUTION

FAST CHANGES IN MOVEMENT

Always attach the motor to a fixed structure before use.

HOT PLUGGING!

Do not connect or disconnect power, logic, or communication while the device is in a powered state.

ENVIRONMENT

- Install the motor only in environments that meet the requirements for its protection class.
- Do not step on or place a heavy object on the motor. Failure to observe this caution may result in injury.
- Be sure to prevent any foreign objects from entering the product. Failure to observe this caution may result in malfunction or fire

CABLES

Do not damage the cables or subject them to excessive stress such as bending or stretching. Do not place heavy objects on the cables or the cables between other objects where they might be pinched.

Check the wiring to be sure it has been performed correctly. Always confirm the pin layouts in technical documents for your model before operation.

Failure to follow these instructions can result in equipment damage.

⚠ WARNING

SAFETY PRECAUTIONS

Make sure necessary safety precautions are taken (emergency stop or other safety features) when installing the motor.

ACCESS TO MOVING PART

Always ensure that no personnel can access the motor before operation as it has accessible moving parts.

HEAT

The motor will become hot during operation, so do not touch the motor with bare hands. Failure to observe this caution may result in burns.

MODIFICATIONS

Do not attempt to disassemble, repair, or modify the product.

Do not change any wiring while power is being supplied.

Failure to follow these instructions can result in death or serious injury

Introduction

The Simplex Motion Speed mode motors are designed for easy installation and configuration, making it an ideal solution for speed controlled applications.

Installation and operation

1. Securely fasten the motor mechanically.
2. Connect the motor electrically according to the schematic.

Pin 1: Variable input 0-3,3/5V for control of the speed.

Pin 2: Variable input 0-3,3/5V for control of the torque. The input also controls the start and stop of the motor. If no limitation of the torque is required, connect a switch directly to 3,3/5V.

Pin 3: Rotational direction control.

High = CW,
Low = CCW.

Pin 4: Alarm output indication one of the following errors:

High/low current
High/low voltage
Temperature

The alarm is automatically reset after 10s.

Pin 5 and 6: Encoder A and B quadrature signal output. Resolution 1024PPR

Pin 7: High or low speed

High = 0-6000 rpm
Low = 0-400 rpm

simplex motion

Pin 8: Programming

Initiate programming mode by connecting pin 8 to ground. Connect pin 2 to ground for 1s. The motor will buzz 1-3 times depending on what setting is set.

To change setting, connect pin 2 to ground again and the motor will buzz 1-3 times again to indicate the new setting. To save the setting and leave the programming mode, disconnect pin 8 from ground.

Setting 1: RampMax = 5000

Setting 2: RampMax = 1000

Setting 3: RampMax = 100

The motor is set to setting 1 as default.

Pin	Function
1	Speed regulation
2	Start/Stop & Torque limitation
3	Rotation direction
4	Alarm signal
5	Encoder A
6	Encoder B
7	Speed High / Low
8	Programming

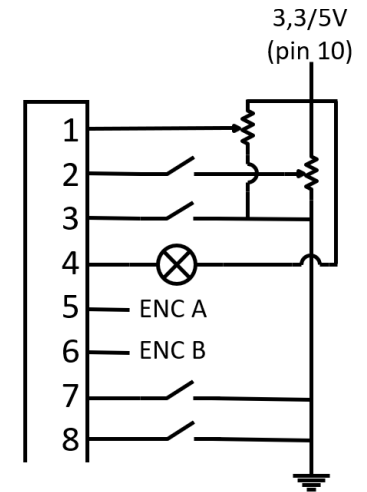

Specifications	SC010	SC020	SC040	SM100	SH100	SH200
Speed	0-6000 rpm	0-6000 rpm	0-6000 rpm	0-6000 rpm	0-6000 rpm	0-6000 rpm
Speed nom.	4000 rpm	4000 rpm	4000 rpm	3000 rpm	3000 rpm	4000 rpm
Torque	0 - 200 mNm	0 - 400 mNm	0 - 800 mNm	0 - 2 Nm	0 - 2 Nm	0 - 4 Nm
Torque nom.	60 mNm	120 mNm	240 mNm	0,32 Nm	0,51 Nm	0,72 Nm
Power nom.	25 W	50 W	120 W	100 W	160 W	300 W
Voltage	12 V	12 - 24 V	12 - 24 V	12 - 24 V	12 - 24 V	24 - 48 V
Control Voltage	0 - 3,3 V	0 - 3,3V	0 - 3,3V	0 - 5V	0 - 5V	0 - 5V